

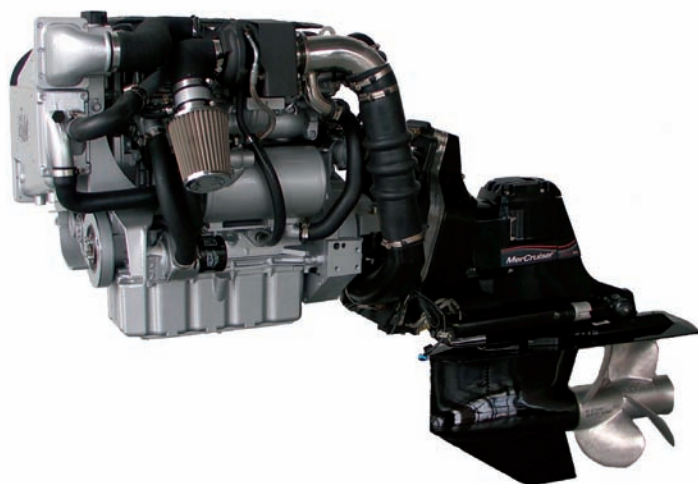

MARINE DIESEL ENGINES



FNM HPEP 150

Configuration	4-stroke cycle, twin camshaft, 16 V
Maximum output at crankshaft	110 kW/150 hp at 4000 rpm
Maximum output at propeller	103 kW/140 hp at 4000 rpm
Maximum torque	311Nm a 2600 giri/min.
Displacement	1.910 c.c.
Bore x stroke	82 x 90,4 mm
Cylinders	4, in-line
Combustion system	Direct injection Common rail
Aspiration	Supercharged with variable geometry turbo
Starting system	Electric starting 12 V – 2,1 kW
Alternator	14 V – 105 A
Cooling system	Double water cooling system with heat exchanger
Lubrication system	Totally enclosed, forced lubricating system with pump
Max. mounting inclination	14°
Dry weight without stern drive	240 kg
Environmental	RCD 2003/44/CE ed EPA TIER 2
Engine mounting	Rubber type anti-vibration mounting

Power according ISO 8665, tolerance 5%, Diesel fuel according EN 590

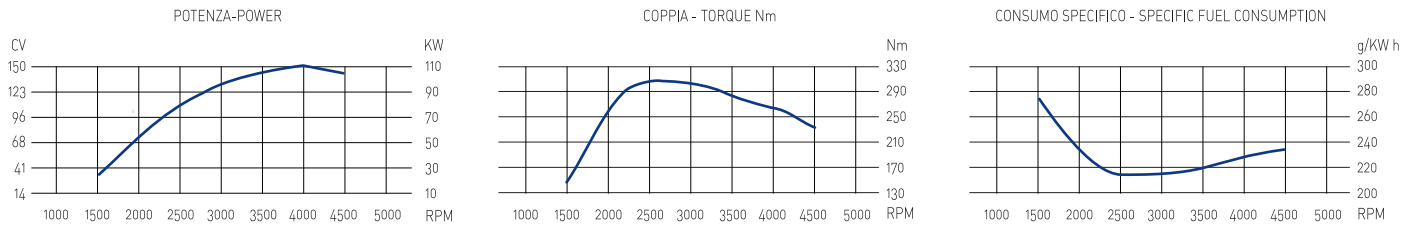

Dimensions (For detailed line-drawings, please refer to our website www.fnm-marine.com or contact your supplier)

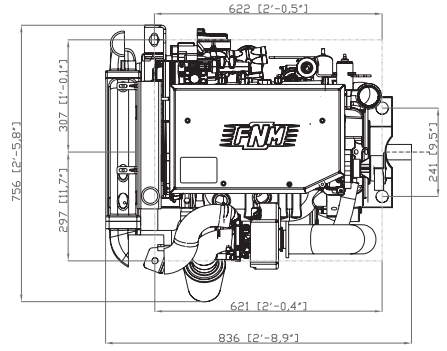
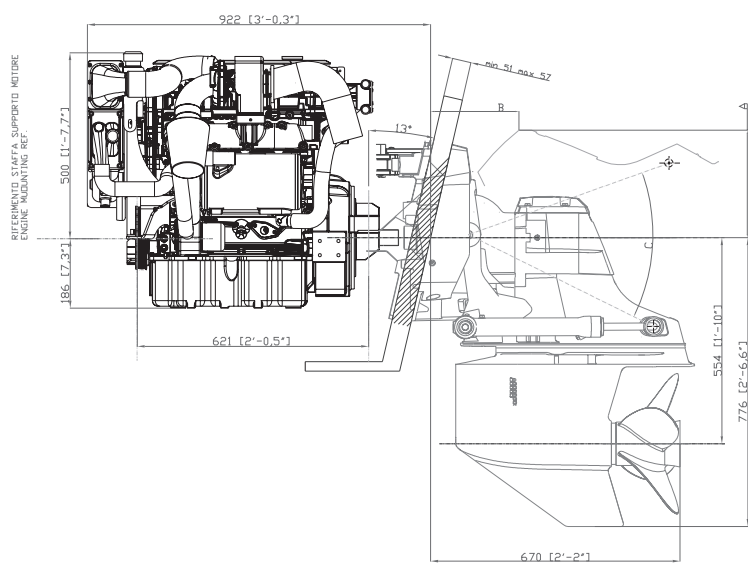

EXHAUST RISER DIAMETER 80mm
 FUEL LINE INLET DIAMETER 8mm
 SEA WATER LINE INLET DIAMETER 32mm

FNM **HPEP 150 w/** Bravo X-1 stern drive

DISTANZIAT.	A	B	C
0	289 [11.37"]	264 [10.39"]	51°
1	274 [10.78"]	286 [11.26"]	46°
2	258 [10.15"]	305 [12.00"]	41°

Available also with Bravo Two and Bravo Three stern drives

Instrument Panel

- VDO Oil pressure
- VDO Water temperature
- VDO Voltmeter
- VDO Rpm counter
- VDO Trim gauge
- 8 meter cable

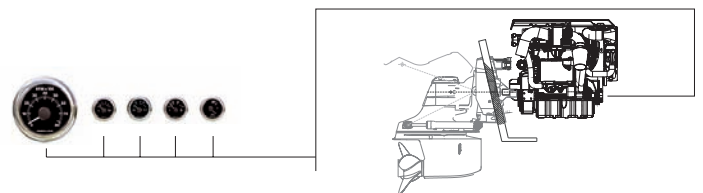

Accessories

Standard Package

- Bravo X-1 stern drive Red. 1,65:1
- Transom
- Set of flexible mounts
- Alternator 14 V – 105 A with built-in regulator
- Starter motor 12 V – 2,1 kW
- Oil and fuel filters
- Water-cooled exhaust manifold
- Bronze seawater pump

- Stainless steel seawater-cooled elbow
- High riser mixing and exhaust mixing elbows
- Original Mercruiser power steering system (complete)
- Racor filters
- Exhaust riser
- Instrument panel with 8 mt. cable and separate VDO gauges
- Engine top cover

Optional

- Dashboard single and double remote control
- CAN single and double remote control
- "Mirage" stainless steel propeller for Bravo X-1
- Multiple Sterndrive Steering Tie Bar Arrangement
- Kit for boat internal heating
- 2 mt. auxiliary extension cable
- Flybridge instrument panel

Text and illustrations are not binding. CMD, owner of the FNM brand, reserves the right to introduce adaptations without prior notification. Compliant with the RCD 2003/44/CE and EPA TIER 2 emission standards.

