

This high thrust MJP UltraJet is specifically introduced for Seismic, Landing Craft, Cargo carrying, Commercial and Military Tow vessel applications, where high static thrust is a prerequisite.

MJP UltraJet 340HT

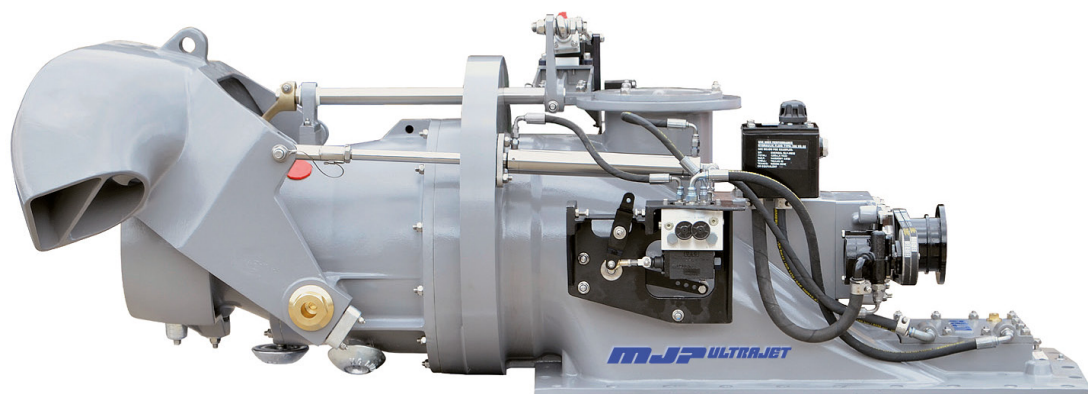

Lloyds ISO9001 Approved

Features & Benefits

- Excellent resistance to cavitation in displacement craft – high thrust at low speed
- Light weight and compact design with a variety of on jet mounted control systems
- Superior manoeuvrability. Ability to accelerate quickly, reverse, stop, rotate, hold station and move sideways for ease of docking.
- Higher mid-range thrust for improved cruising speed and economy
- Lower vibration and noise levels than other propulsion methods
- Wide range of Ultra-developed mechanical and electrical reversing controls
- Standard rubber impeller shaft bearing or optional composite bearing if dry running is required

Description

MJP UltraJet 340 High Thrust (HT) is a derivative of the UltraJet 340 – which has been in service world-wide for 10 years. The UJ340HT has the same major installation dimensions and can be installed into a similar space envelope. Incorporating an efficient and robust axial flow pump, reverse and steering controls, it has many of the same design features as used in the current “UltraJet range”. The proven 4 and 5 bladed impeller design is less susceptible to mechanical damage than multi bladed designs.

To achieve superior thrust, design improvements have been made to the intake and impeller of the UJ340HT. This high thrust unit was specifically introduced into the UltraJet range for Seismic, Landing Craft, Cargo carrying, Commercial and Military Tow vessel applications, where high static thrust is a prerequisite.

Planing Craft

Maximum input power 410 kW (550 HP)

Single jet up to 12 tonnes (26,448 lb.)

Twin jets up to 26 tonnes (57,304 lb.)

Triple jets up to 42 tonnes (92,568 lb.)

Displacement Craft

Maximum input power 280 kW (375 HP)

Single jet up to 20 tonnes (44,080 lb.)

Twin jets up to 45 tonnes (98,180 lb.)

Triple jets up to 90 tonnes (198,360 lb.)

Note: The displacement figures can often be exceeded on good hull shapes.

MJP UltraJet 340HT

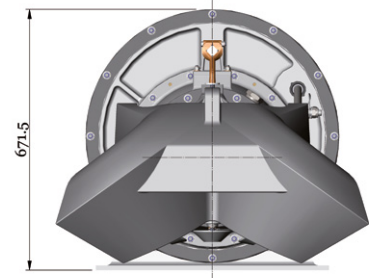
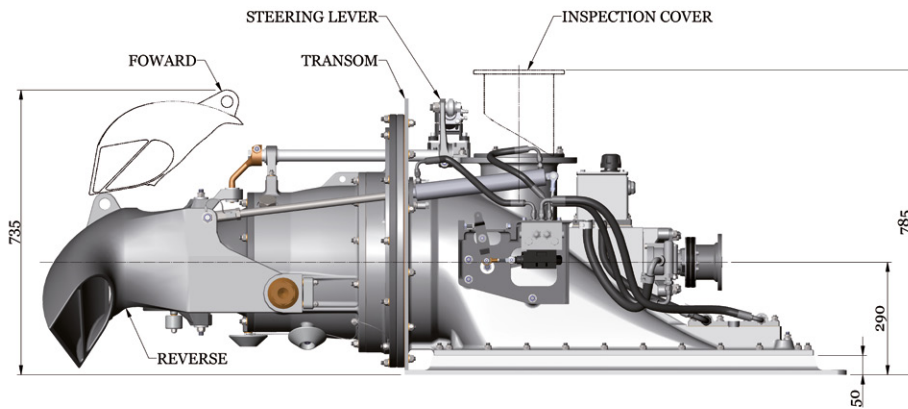

OUTBOARD VIEW OF ULTRAJET UNIT

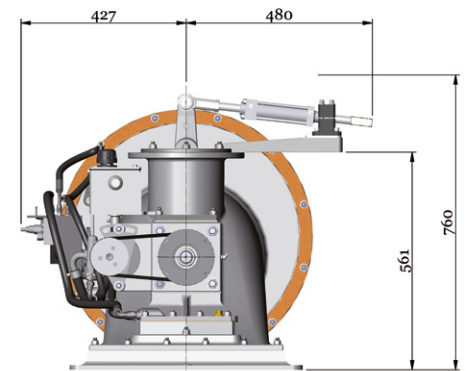
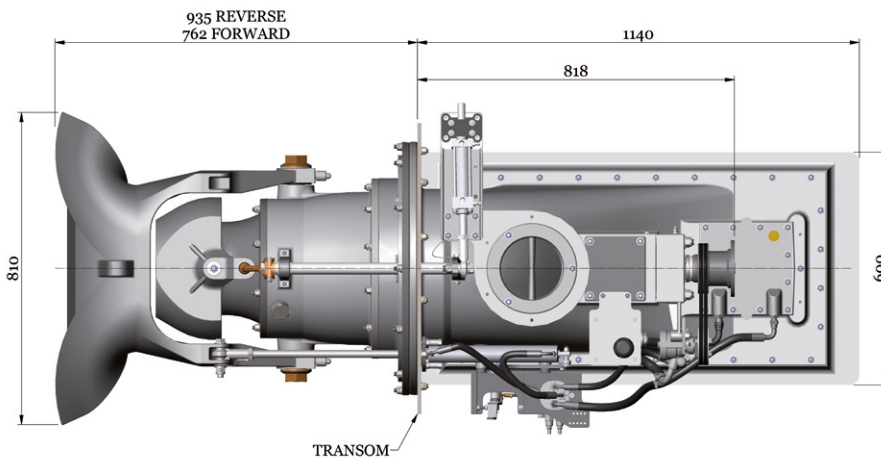

INBOARD VIEW OF ULTRAJET UNIT

Typical Specifications:

1. Impellers are available to match most diesel and gasoline engine and transmission combinations for optimum thrust performance.
2. DIN, SAE or other drive flange options can be supplied.
3. Unit weight 320 kg (706 lb) dry (Includes hydraulic system and controls). 352 kg (777 lb) including entrained water.
4. Consult Marine Jet Power Technical Department for vessel and performance analysis.

We have a policy of continuous improvement in design. Specifications may, therefore, be changed without notice. When considering applications for this equipment it is recommended that our Technical Sales Department is consulted.