

N3.21

Specifications

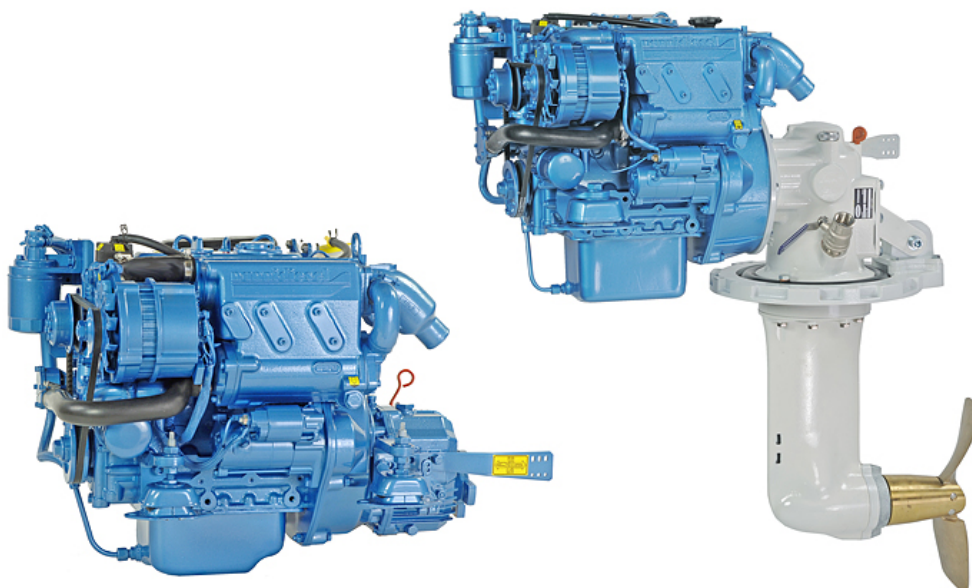

Power at crankshaft	15.44 kW [21 hp]
Displacement	0.719 l [44 in ³]
Configuration	3 cylinders in line
Operation type	4 stroke Diesel
Bore & Stroke	67 x 68 mm [2.64 x 2.68 in]
Compression ratio	23.5:1
Rated speed	3600 rpm
Idle speed	1050 rpm
Peak torque	47 Nm
Peak torque speed	2600 rpm
Dry weight	
with TMC40	106 kg [233 lb]
with Sail Drive SP60	142 kg [313 lb]

Engine base	Kubota
Fuel system	Mechanical indirect injection
Air intake	Natural
Cooling	Closed cooling with heat exchanger
Mounting angle	15° Front up 15° Front down
Alternator	12 Volt 70 Amp
Rating	M5
Emission compliance	EPA marine Tier 3 RCD 94/25/EC BSO 2

N3.21

15.44 kW [21 hp] @ 3600 rpm

TECHNICAL DESCRIPTION

Engine block

- 3 cylinders in line
- Gear-driven valve train
- Watercooled exhaust manifold

Fuel system

- Mechanical governor
- Cam driven in-line injection pump
- Fuel feed pump with hand primer
- Fuel filter

Lubrication system

- Replaceable full-flow oil filter
- Oil dipstick
- Oil drain pump

Cooling system

- Closed cooling with heat exchanger
- Gear driven self-priming raw water pump
- Coolant circulating pump
- Water cooled exhaust elbow

Electrical system & Instrumentation

- 12V Electrical system
- 12V 70A alternator
- Electric starter motor
- Electric stop function
- Instrumentation panel, including Start/Stop, tachometer & alarms
- Extension cable harness with plug-in connection

Air intake

- Mounted air cleaner

Other features

- Flexible engine mounting
- Bracket for control cables

Optional equipment & accessories

- Keel cooling adaptation
- Complete marine propulsion systems
- Throttle and shift controls
- Additional instrumentation, Flying bridge extension harness
- Polyester frame (for Sail Drive version)
- Engine mounting adaptation
- Two pole electrical system
- Water boiler systems
- Stuffing box connections
- Complete fuel systems
- Complete exhaust systems

RATING

- Up to 1000 annual operating hours
- Load factor up to 35%
- Full power for no more than 30 minutes out of each 8 hours of operation. The remaining operation time must be at or below cruising speed

TRANSMISSIONS

Shaft line

- TMC40
- TTMC35A

Sail Drive

- SP60

Contact your local dealer for more details and availability for transmission model and type.

PERFORMANCE CURVES

Power at crankshaft

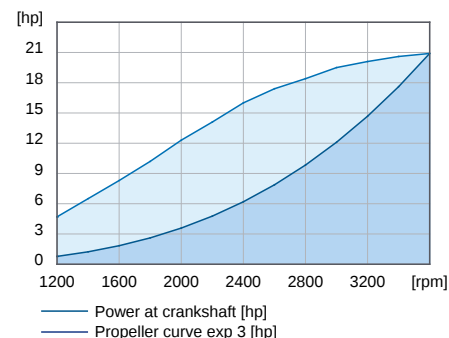

Torque at crankshaft

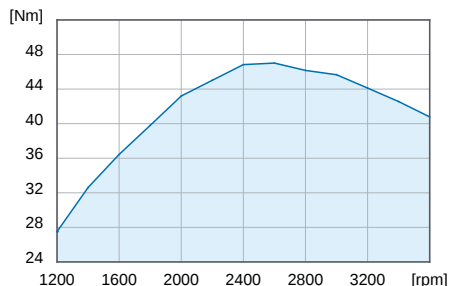

Fuel consumption

At calculated propeller load exp 3

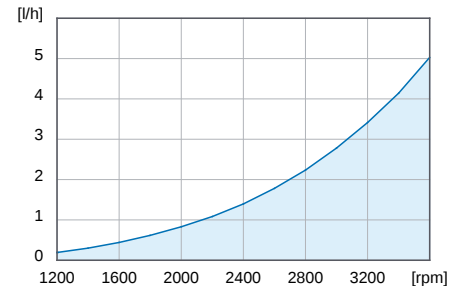

DIMENSIONS WITH SP60 / TMC40

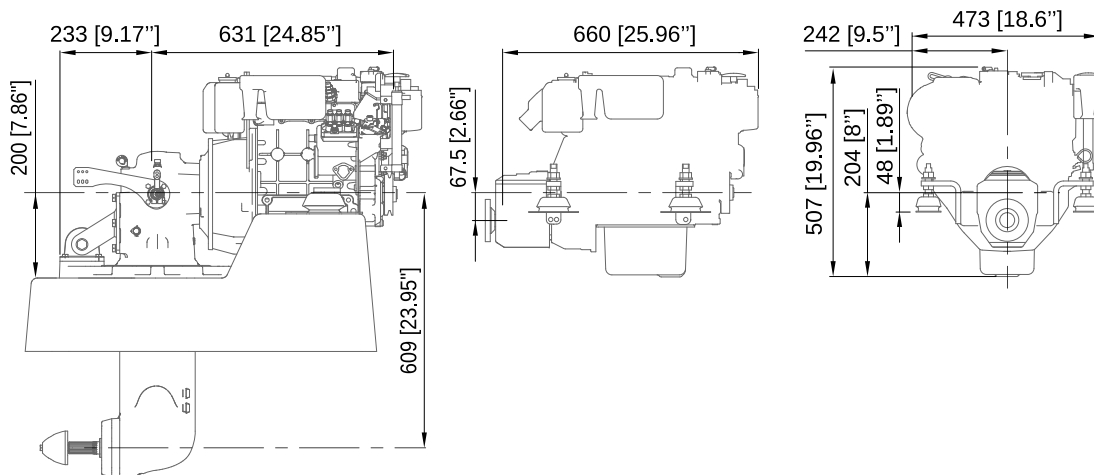

Nanni Industries S.A.S. France

11, Avenue Mariotte - Zone Industrielle
33260 La Teste - France
Tel: +33 (0)5 56 22 30 60
Fax: +33 (0)5 56 22 30 79

Nanni Trading S.R.L.

Via Degli Olmetti, 5/B
00060 Formello (RM) - Italia
Tel: +39 (0)6 30 88 42 51/52/53
Fax: +39 (0)6 30 88 42 54

Technical data according to ISO 8665. Specifications are subject to change without notice. Images and illustrations may show non standard equipments. All combination of equipment & accessory are not available.

150715-ENG